



Constant Power Delivery Utilising TRAC

Kambiz Pourhady

The TRAC family of totally reconfigurable Field Programmable Analog Devices offers an integrated path from signal processing problems to working silicon solutions - in minutes!

Introducing a Top-Down, Structured design discipline, TRAC enables rapid implementation, prototyping and product release. Rather than designing at the component level, TRAC champions a Computational Approach. Using eight simple mathematical building-blocks, any transfer function can be implemented on TRAC, and more besides!

With a combination of programmable silicon and design software, TRAC brings a truly Integrated Route to signal processing problem solving, providing designers with benefits formerly associated only with programmable digital devices, and offering a path to Custom Silicon for higher volume users.

Introduction

The requirement for Constant Power will exist in the majority of electrical and electronic products. This application note demonstrates meeting this demand in the case of High Intensity Discharge (HID) Lamp drivers. However, the same topology may be applied across a wide spectrum of applications such as Motor Control, UPS, Power Generation, Lighting, Disk Drives and many other areas.

Theory of Application

TRAC, coupled with the Zetex FZT789 (SOT223) Switching Transistor, can easily achieve the constant power delivery required. This is outlined in the block diagram, Figure 1.

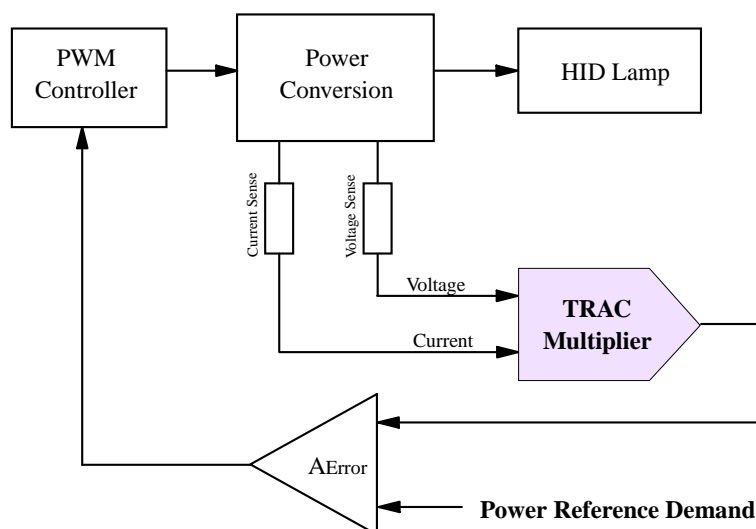

Figure 1
HID Driver block diagram

The required power is set by the "Power Reference Demand" (PRD) input. This input is constantly compared with the output of the TRAC, where the voltage and current supplied to the HID are monitored and multiplied to give a measure of the power being supplied. Constant power delivery to the lamp is maintained by varying the mark-space ratio of the Pulse Width Modulator (PWM).

In Figure 1, TRAC has been configured as a Multiplier. Compared to presently available Multiplier ICs (where the output product is always scaled and the multiplier device needs a number of Resistors, Capacitors and Potentiometers to function), TRAC is considered to be the most versatile and cost effective solution.

Software

Adopting the 'computational approach', the TRAC multiplier design, adds the logarithms of the monitored Voltage and Current components and then takes the antilogarithm, as shown in Figure 2. Minimised external circuitry delivers the sampled "Voltage Component" input to I/O1, while the sampled "Current Component" input is fed directly to I/O8. In order to ensure that the signal to the ANTiLog cell remains within its 0.1V to 0.8V working range, in this type of multiplier it is necessary to 'divide by one' after all but the final input, and the 1V DC input to I/O2 achieves this. If offset trimming is needed, this voltage can be adjusted.

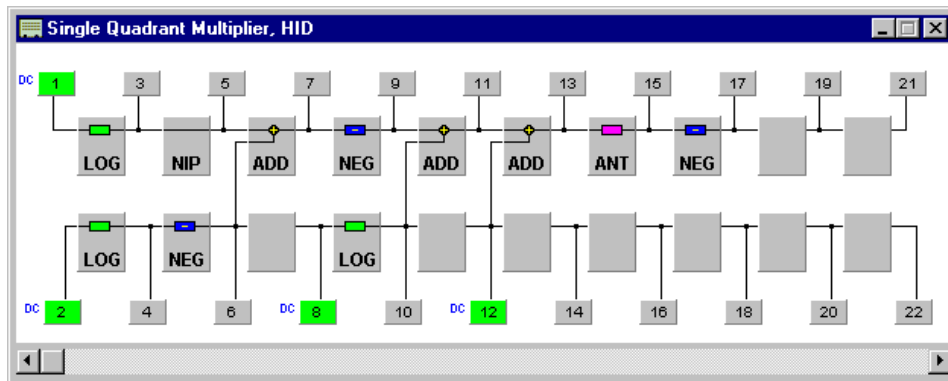

Figure 2
TRAC Single Quadrant Multiplier

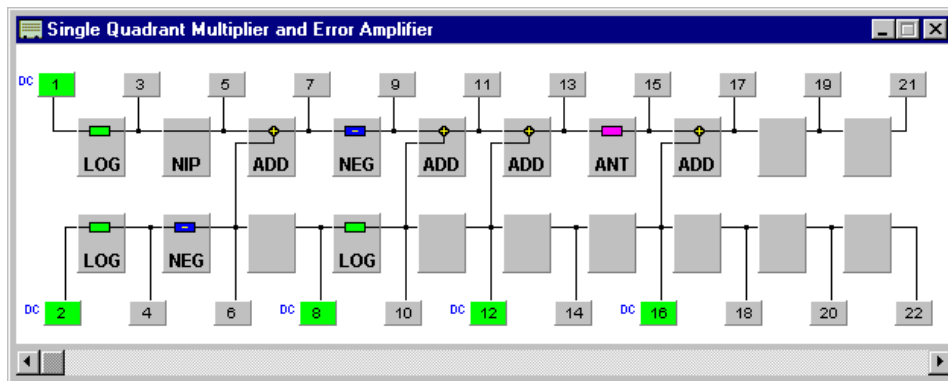

Figure 3
TRAC Single Quadrant Multiplier with Error Amplifier

The product of voltage and current at IO15 is fed to an Error Amplifier (ADD function), where it is subtracted from the "Power Reference Demand", for corrective action via the Pulse Width Modulator (PWM, TL5001) thus, keeping the delivered power to the load constant.

TRAC Application Note AN10
Issue 1 September 1998

NOTES:

Fast Analog Solutions Ltd.
Fields New Road, Chadderton, Oldham, OL9 8NP, United Kingdom.
Tel: (+44) (0) 161 622 4567 Fax: (+44) (0) 161 622 4568
e-mail: trac@fas.co.uk Internet: <http://www.fas.co.uk>



TRAC products are supported by agents and distributors in many countries of the world. Details can be found on our web site.



A ZETEX GROUP COMPANY

This publication is issued to provide outline information only which (unless agreed by the Company in writing) may not be used, applied or reproduced for any purpose or form part of any order or contract or be regarded as a representation relating to the products or services concerned. The Company reserves the right to alter without notice the specification, design, price or conditions of supply of any product or service.

TRAC

TAN10-4