



## Bipolar Analog Switch Utilising TRAC

**Ian Shaw**

The TRAC family of totally reconfigurable Field Programmable Analog Devices offers an integrated path from signal processing problems to working silicon solutions - in minutes!

Introducing a Top-Down, Structured design discipline, TRAC enables rapid implementation, prototyping and product release. Rather than designing at the component level, TRAC champions a Computational Approach. Using eight simple mathematical building-blocks, any transfer function can be implemented on TRAC, and more besides!

With a combination of programmable

silicon and design software, TRAC brings a truly Integrated Route to signal processing problem solving, providing designers with benefits formerly associated only with programmable digital devices, and offering a path to Custom Silicon for higher volume users.

### Introduction

In this application TRAC acts as an electronic switch. A waveform applied to the input is passed through to the output only when control signal is positive.

The switching input can be sine, square, sawtooth or indeed any waveform which passes through zero volts.

**Theory of Application**

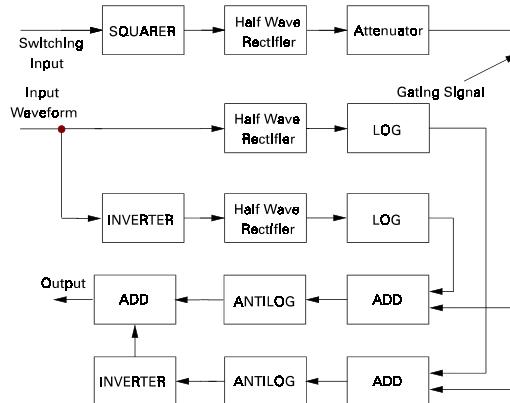

**Figure 1**  
**Block Diagram of Bipolar Analog Switch**

The first process is to square the switching waveform by saturating the LOG function resulting in an essentially square waveform which is then half wave rectified leaving just the positive half. (See Figure 2). This will always be about 750 mV due to the LOG function. For reasons, which will be explained in the next section, this is then halved in value to about 375 mV and will be referred to as the gating signal.

rectified (on both halves) resulting in two separate paths which are transferred to the log domain independently. Again the value of both these waveforms will be about 750 mV. See Figure 3. (NB This graph has been plotted to a different time axis for clarity)

The main input waveform is half wave

The waveform shown in Figure 3 and the gating pulse are then added and the result is shown in Figure 4

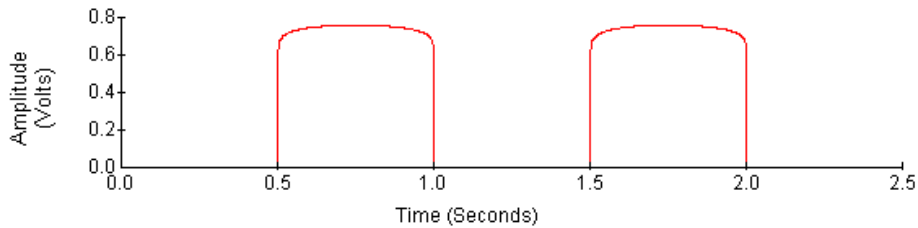
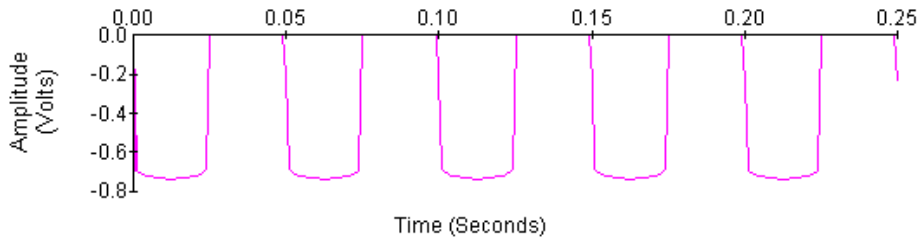

**Figure 2**  
**Waveform at I/O 4**

**TRAC Application Note AN9**  
**Issue 1 September 1998**

---

When this waveform is transformed to the linear domain the 0.4 volt level equates to a very small voltage but the sections which have not been shifted result in the original half wave rectified input waveform shown in Figure 5.



**Figure 3**  
**Waveform at I/O 15**

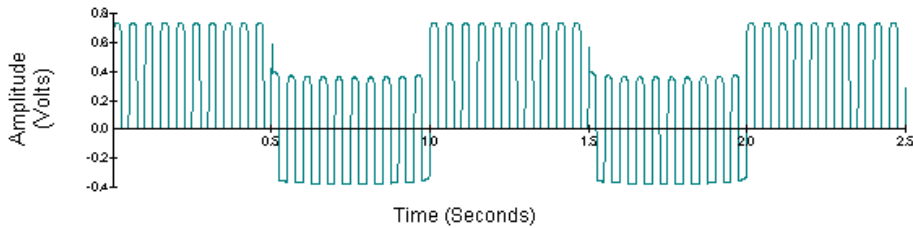

**Figure 4**  
**Waveform at I/O 17**

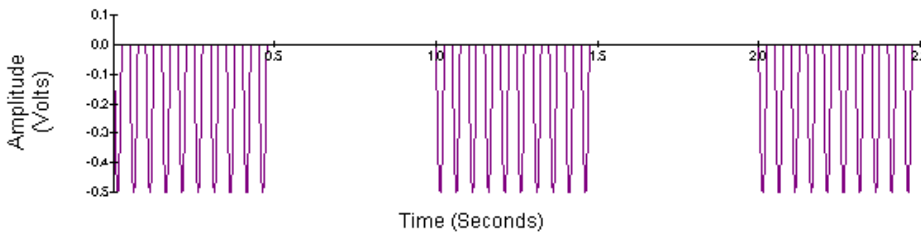

**Figure 5**  
**Waveform at I/O 19**



## TRAC Application Note AN9 Issue 1 September 1998

---

This is then combined with the waveform from the other path to give the complete switched waveform. This is shown in Figure 6 with the switching waveform superimposed.

### Software

Figure 7 shows the bipolar analog switch implemented in two TRAC chips. The switching waveform is applied to I/O 1, the input waveform to I/O 7 and the output appears on I/O 35.

### Hardware

The only external components required for the switch are around the amplifier used to attenuate the switching waveform.

Suitable values for the amplifier (gain = 0.5) are  $R_{input} = 3.0k\Omega$  and  $R_{feedback} = 1.5k\Omega$

These are only suggested values in this application. In practice values in the range 1k - 100 k $\Omega$  would be suitable.

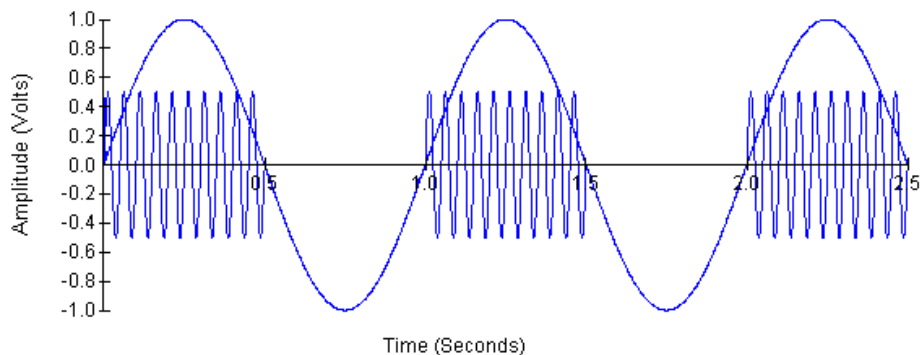

**Figure 6**  
**Output and Switching Waveforms**



**TRAC Application Note AN9  
Issue 1 September 1998**

---

**NOTES:**

---

***TRAC***

TAN9-6

NOTES:

**TRAC Application Note AN9  
Issue 1 September 1998**

---

**NOTES:**

Fast Analog Solutions Ltd.  
Fields New Road, Chadderton, Oldham, OL9 8NP, United Kingdom.  
Tel: (+44) (0) 161 622 4567 Fax: (+44) (0) 161 622 4568  
e-mail: [trac@fas.co.uk](mailto:trac@fas.co.uk) Internet: <http://www.fas.co.uk>



TRAC products are supported by agents and distributors in many countries of the world. Details can be found on our web site.



A ZETEX GROUP COMPANY

---

This publication is issued to provide outline information only which (unless agreed by the Company in writing) may not be used, applied or reproduced for any purpose or form part of any order or contract or be regarded as a representation relating to the products or services concerned. The Company reserves the right to alter without notice the specification, design, price or conditions of supply of any product or service.

---

**TRAC**

TAN9-8