

REF01

+10V Precision VOLTAGE REFERENCE

FEATURES

- **OUTPUT VOLTAGE:** +10V $\pm 0.2\%$ max
- **EXCELLENT TEMPERATURE STABILITY:** 8.5ppm/ $^{\circ}\text{C}$ max (-40°C to $+85^{\circ}\text{C}$)
- **LOW NOISE:** 5 μV p-p typ (0.1Hz to 10Hz)
- **EXCELLENT LINE REGULATION:** 0.001%/V max
- **EXCELLENT LOAD REGULATION:** 0.002%/mA max
- **SOURCES 10mA, SINKS 5mA min**
- **LOW SUPPLY CURRENT:** 1.4mA max
- **SHORT-CIRCUIT PROTECTED**
- **WIDE SUPPLY RANGE:** 11.4VDC to 40VDC
- **PACKAGE OPTIONS:** Plastic DIP, SOIC
- **EXTENDED INDUSTRIAL TEMPERATURE RANGE:** -40°C to $+85^{\circ}\text{C}$

APPLICATIONS

- PRECISION REGULATORS
- CONSTANT CURRENT SOURCE/SINK
- DIGITAL VOLTMETERS
- A/D AND D/A CONVERTERS
- PRECISION CALIBRATION STANDARD
- TEST EQUIPMENT

DESCRIPTION

The REF01 is a high performance, low price, precision pin compatible second source voltage reference. Output accuracy of $\pm 0.2\%$ is a 30% improvement over industry standard REF01s. Output noise is 5 μV p-p, which is a 75% decrease in noise over all other REF01s. Line regulation is 0.001%/V max and load regulation is 0.002%/mA max, which far exceeds the performance of our competitors. Quiescent current is a low 1.4mA. REF01 provides extended supply range when compared to industry standard devices. Burr-Brown's REF01 is the best choice for applications which requires improved accuracy, low noise, low power consumption, low drift, and the lowest price. Popular package options are available: Plastic DIP, and SOIC. For guaranteed long-term drift see Burr-Brown's model REF10.

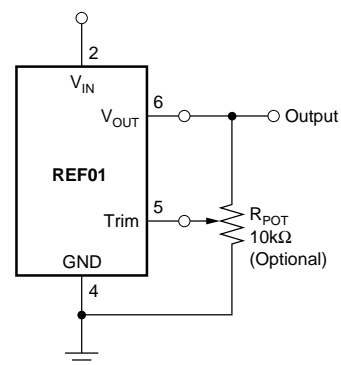

SPECIFICATIONS

ELECTRICAL

At $T_A = +25^\circ\text{C}$ and $V_S = +15\text{V}$ power supply, unless otherwise noted.

PARAMETER	CONDITIONS	REF01A			REF01B			REF01C			UNITS
		MIN	TYP	MAX	MIN	TYP	MAX	MIN	TYP	MAX	
OUTPUT VOLTAGE (ΔV_{OT}) Change with Temperature ^(1, 2) -40°C to +85°C	$I_L = 0\text{mA}$	9.970	10.0	10.030	9.975	10.0	10.025	9.980	10.0	10.020	V
			0.11	0.18		0.06	0.11		0.04	0.07	%
OUTPUT VOLTAGE DRIFT ⁽³⁾ -40°C to +85°C (TCV _O)			10	25		8	15		3	8.5	±ppm/°C
OUTPUT ADJUSTMENT RANGE	$R_{POT} = 10\text{k}\Omega$ ⁽⁶⁾	±3			±3			±3			%
CHANGE IN V_O TEMP COEFFICIENT WITH OUTPUT ADJUSTMENT (-55°C to +125°C)	$R_{POT} = 10\text{k}\Omega$		0.5			0.5			0.5		ppm/%
OUTPUT VOLTAGE NOISE	0.1Hz to 10Hz ⁽⁵⁾		5			5			5		µVp-p
LINE REGULATION ⁽⁴⁾ -40°C to +85°C	$V_{IN} = 11.4\text{V}$ to 36V		0.001	0.003		0.0007	0.002		0.0003	0.001	%/V
			0.002	0.006		0.001	0.004		0.001	0.002	
LOAD REGULATION ⁽⁴⁾ -40°C to +85°C	$I_L = 0\text{mA}$ to +10mA $I_L = 0\text{mA}$ to -5mA $I_L = 0\text{mA}$ to +10mA		0.001	0.004		0.001	0.003		0.001	0.002	%/mA
			0.003	0.008		0.002	0.006		0.001	0.004	
			0.005	0.016		0.004	0.012		0.003	0.008	
TURN-ON SETTLING TIME	$T_o \pm 0.1\%$ of Final Value		5			5			5		µs
QUIESCENT CURRENT	No Load		1.2	1.4		1.2	1.4		1.2	1.4	mA
LOAD CURRENT		10	21		10	21		10	21		mA
SINK CURRENT		-5	-10		*	*		*	*		mA
SHORT-CIRCUIT CURRENT	$V_O = 0$		30			30			30		mA
POWER DISSIPATION			18			18			18		mW
TEMPERATURE RANGE Specification REF01A, B, C		-40		+85	*		*	*		*	°C

NOTES: (1) ΔV_{OT} is defined as the absolute difference between the maximum output and the minimum output voltage over the specified temperature range expressed as a percentage of 10V: $\Delta V_O = \frac{|V_{MAX} - V_{MIN}|}{10V} \times 100\%$. (2) ΔV_{OT} specification applies trimmed to +10.000V or untrimmed. (3) TCV_O is defined as ΔV_{OT} divided

by the temperature range. (4) Line and load regulation specifications include the effect of self heating. (5) Sample tested. (6) 10kΩ potentiometer connected between V_O and ground with wiper connected to trim pin. See Figure 3.

The information provided herein is believed to be reliable; however, BURR-BROWN assumes no responsibility for inaccuracies or omissions. BURR-BROWN assumes no responsibility for the use of this information, and all use of such information shall be entirely at the user's own risk. Prices and specifications are subject to change without notice. No patent rights or licenses to any of the circuits described herein are implied or granted to any third party. BURR-BROWN does not authorize or warrant any BURR-BROWN product for use in life support devices and/or systems.

ABSOLUTE MAXIMUM RATINGS

Input Voltage	+40V
Operating Temperature P, U	-40°C to +85°C
Storage Temperature Range P, U	-65°C to +125°
Output Short Circuit Duration (to Ground or V_{IN})	Indefinite
Junction Temperature	-65°C to +150°
θ_{JA} P	120°C/W
U	80°C/W
Lead Temperature (soldering, 60s)	+300°C



ELECTROSTATIC DISCHARGE SENSITIVITY

This integrated circuit can be damaged by ESD. Burr-Brown recommends that all integrated circuits be handled with appropriate precautions. Failure to observe proper handling and installation procedures can cause damage.

ESD damage can range from subtle performance degradation to complete device failure. Precision integrated circuits may be more susceptible to damage because very small parametric changes could cause the device not to meet its published specifications.

PIN CONFIGURATIONS

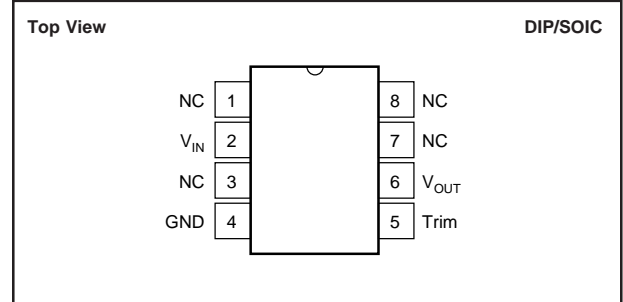

PACKAGE INFORMATION

PRODUCT	PACKAGE	PACKAGE DRAWING NUMBER ⁽¹⁾
REF01AU	8-Pin SOIC	182
REF01BU	8-Pin SOIC	182
REF01AP	8-Pin Plastic DIP	006
REF01BP	8-Pin Plastic DIP	006

NOTE: (1) For detailed drawing and dimension table, please see end of data sheet, or Appendix C of Burr-Brown IC Data Book.

ORDERING INFORMATION

PRODUCT	V_{OUT} AT 25°C	MAX DRIFT (ppm/°C)	TEMPERATURE	PACKAGE
REF01AU	10V±30mV	±25	-40°C to +85°C	8-Pin SOIC
REF01BU	10V±25mV	±15	-40°C to +85°C	8-Pin SOIC
REF01AP	10V±30mV	±25	-40°C to +85°C	8-Pin Plastic DIP
REF01BG	10V±25mV	±15	-40°C to +85°C	8-Pin Ceramic DIP
REF01BP	10V±25mV	±15	-40°C to +85°C	8-Pin Plastic DIP

TYPICAL PERFORMANCE CURVES

At $T_A = +25^\circ\text{C}$ and $V_S = +15\text{V}$ power supply, unless otherwise noted.

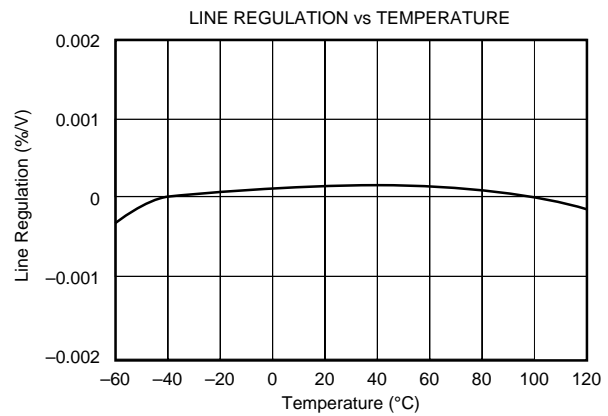
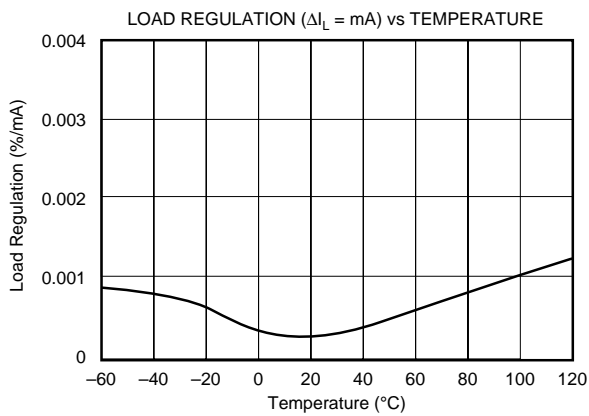
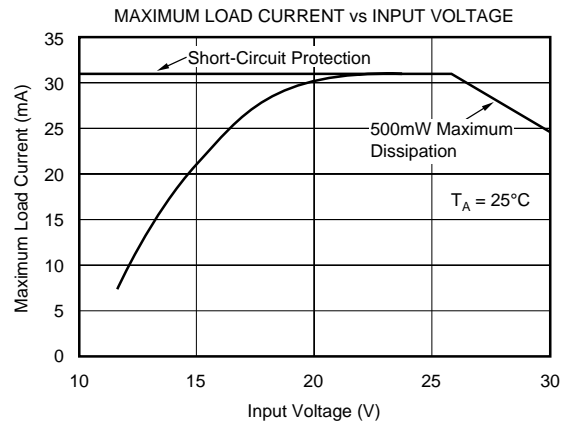
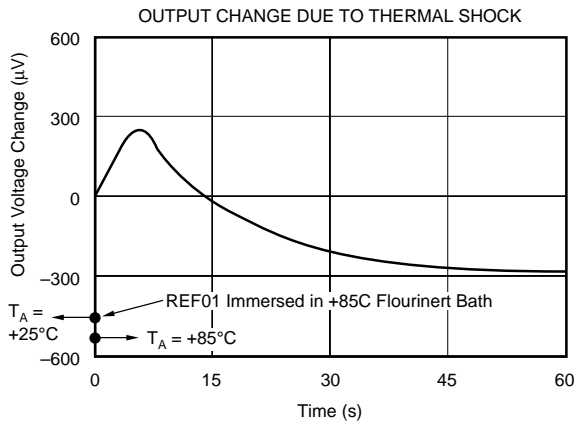
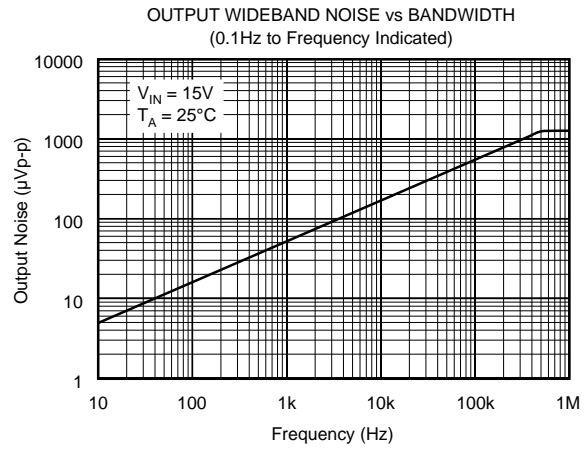
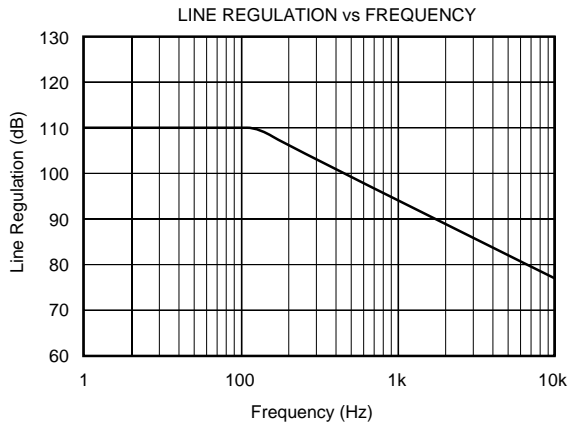

TYPICAL PERFORMANCE CURVES (CONT)

At $T_A = +25^\circ\text{C}$ and $V_S = +15\text{V}$ power supply, unless otherwise noted.

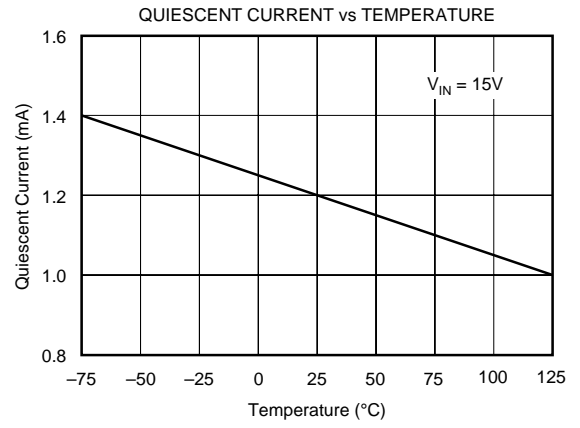
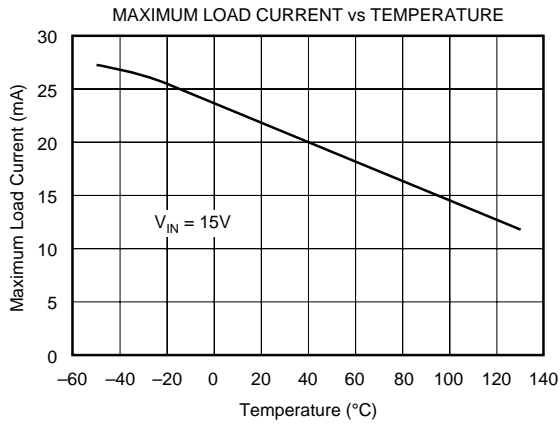

OUTPUT ADJUSTMENT

The REF01 trim terminal can be used to adjust the voltage over a 10V $\pm 300\text{mV}$ range. This feature allows the system designer to trim system errors by setting the reference to a voltage other than 10V, including 10.240V for binary applications (see circuit on the first page).

Adjustment of the output does not significantly affect the temperature performance of the device. The temperature coefficient change is approximately 0.5ppm/ $^{\circ}\text{C}$ for 100mV of output adjustment.

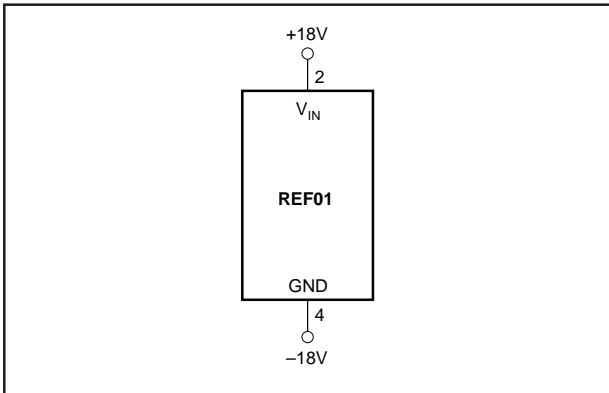

FIGURE 1. Burn-In Circuit.

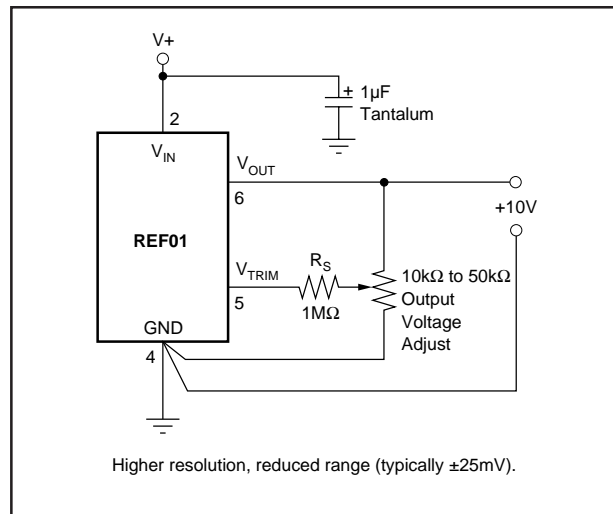

FIGURE 2. High Resolution Output Adjustment.